

## Large Flange Head Jack Nut

**Body Type:** Round Open

**Outside Body:** Smooth

**Thread Type:** Metric - Coarse

**Body Material:** Steel to AISI 1010 1008

**Class Grade:** Low Tensile Class 4.6

**Finish:** Zinc Plated

**Corrosion Protection Level:** Moderate

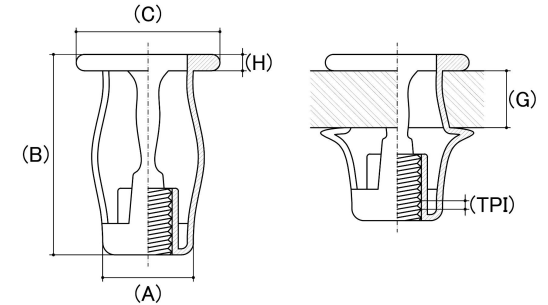

*CAD drawings shown for graphic representation only.\**

Size	Thread Pitch (mm)	Thread Type	Material Grip Range (G) (mm)		Overall Nut Height (B) (mm)	Head Diameter (C) (mm)	Nut Width (A) (mm)	Flange Thickness (H) (mm)	Recommended Hole Size (mm)	sku (qfind)
			Min	Max	Nom	Nom	Nom	Nom	Nom	
M4	0.70	Coarse	0.40	4.70	17.00	11.90	7.50	1.80	7.50	43JN4
M4	0.70	Coarse	4.70	9.50	22.00	11.90	7.50	1.80	7.50	43JN42
M5	0.80	Coarse	4.70	9.50	23.20	13.50	9.00	1.80	9.00	43JN52
M6	1.00	Coarse	0.40	4.70	18.90	16.00	11.00	1.80	11.00	43JN6
M6	1.00	Coarse	4.70	9.50	23.00	16.00	11.00	1.80	11.00	43JN62

**Disclaimer:**

Dimensional data and technical information was obtained from publically available sources and not acquired through standard agencies. It has been completed and compiled for reference purposes only; where discrepancies are found they are subject to change without notice. Bolt & Nut Australia makes no warranties or representations regarding the accuracy and validity of the compiled information and data. Contact the relevant standard authorities for accurate and detailed information.

\* CAD drawings may not reflect diameter, thread length or overall length.

© Bolt & Nut Australia Pty Ltd. All rights reserved.

Version: 18 Mar 2024